

CD Automation UK Ltd

Product Support:

Tel: +44 1323 811100 Email: info@cdautomation.co.uk



Declaration of conformity

Declaration of conformity - Dichiarazione di Conformità

PRODUCT MANUFACTURER / PRODUTTORE:



CD Automation S.R.L.
Controllers, Drives & Automation

Via Picasso, 34/36 - 20025 Legnano (MI)- Italy
P.I. 08925720156 -Tel. +39 0331 577479 - Fax +39 0331 579479
E-mail: info@cdautomation.com - Web: www.cdautomation.com

Declare that the product / Dichiaro che il prodotto:

CD3000S 3PH 15-90A

PRODUCT DESCRIPTION: Electric power control
SCOPE OF APPLICATION: Thermal control process
DESCRIZIONE DEL PRODOTTO: Unità di controllo potenza elettrica
UTILIZZO: Controllo processi termici

FULFILLS THE REQUIREMENTS OF THE STANDARD:

Electrical safety Standard	EN60947-1: 2007 + A1 2011, A2 2014 EN60947-4-3: 2014
Generic Emission standard	EN60947-4-3: 2014 Group 1 Class A emissions
Generic Immunity standard	EN60947-4-3: 2014 Industrial Immunity

SODDISFA I REQUISITI DELLA NORMA:

Specifica di sicurezza	EN60947-1: 2007 + A1 2011, A2 2014 EN60947-4-3: 2014
Specifica sulle emissioni	EN60947-4-3: 2014 gruppo 1 emissioni classe A
Specifica sulle Immunità	EN60947-4-3: 2014 Immunità industriale

CDAutomation declares that the products above mentioned are conforming to the directive
CDAutomation dichiara che i prodotti sopra menzionati sono conformi alla direttiva
Bassa Tensione (low Voltage) **EMC directive updated 2014/30/EU,**
Low Voltage Directive updated 2014/35/EU

Issued on: 20/03/2017
Data di emissione: 20/03/2017

Amministratore Unico e
Legale Rappresentante

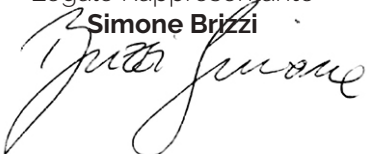
Simone Brizzi









Important warnings for safety

This chapter contains important information for the safety. The not observance of these instructions may result in serious personal injury or death and can cause serious damages to the Thyristor unit and to the components system included.

The installation should be performed by qualified persons.

In the manual are used symbols to give more evidence at the notes of safety and operativity for the attention for the user:

	This icon is present in all the operational procedures where the Improper operation may result in serious personal injury or death by Electrical Shock Hazard Symbol (a lightning bolt in a triangle) precedes an electric shock hazard CAUTION or WARNING safety statement.
	Warning or Hazard that needs further explanation than the label on unit can provide. Consult User's Guide for further information.
	Unit is compliant with European Union directives. See Declaration of Conformity for further details on Directives and Standards used for Compliance.
	If available, unit is a Listed device per Underwriters Laboratories. It has been investigated to ANSI/UL® 508 standards for Industrial Control Switches and equivalent to CSA C22.2 #14. For more detail search for File E231578 on www.ul.com
	ESD Sensitive product, use proper grounding and handling techniques when installing or servicing product.
	Do not throw in trash, use proper recycling techniques or consult manufacturer for proper disposal.

A **"NOTE"** marks a short message to alert you to an important detail.

A **"CAUTION"** safety alert appears with information that is important for protecting your equipment and performance. Be especially careful to read and follow all cautions that apply to your application.

A **"WARNING"** safety alert appears with information that is important for protecting you, others and equipment from damage. Pay very close attention to all warnings that apply to your application.

Safety notes













WARNING! To avoid damage to property and equipment, injury and loss of life, adhere to applicable electrical codes and standard wiring practices when installing and operating this product. Failure to do so could result in damage, injury and death.



AVERTISSEMENT! Pour éviter d'endommager la propriété et l'équipement, les blessures et la perte de vie, respecter les codes électriques en vigueur et les pratiques de câblage standard au moment de l'installation et de l'utilisation de ce produit. Dans le cas contraire, cela peut entraîner la mort, des blessures graves ou des dommages.

-  **WARNING!** All service including inspection, installation, wiring, maintenance, troubleshooting, fuse or other user serviceable component replacement must be performed only by properly qualified personnel. Service personnel must read this manual before proceeding with work. While service is being performed unqualified personnel should not work on the unit or be allowed in the immediate vicinity.
-  **AVERTISSEMENT!** Tous les services, y compris l'inspection, l'installation, le câblage, l'entretien, le dépannage, le remplacement de fusibles ou d'autres composants pouvant être réparés par l'utilisateur, doivent être effectués uniquement par un personnel d'entretien qualifié. Le personnel de service doit lire ce manuel avant d'effectuer tout travail. Pendant que l'entretien est exécuté, tout personnel non qualifié ne doit effectuer de travail sur l'appareil ni se trouver à proximité.
-  **WARNING!** When in use the power controller is connected to dangerous voltages. Do not remove the protective covers without first disconnecting and preventing power from being restored while servicing the unit.
-  **AVERTISSEMENT!** Au moment de l'utilisation, le régulateur de puissance est connecté à des tensions dangereuses. Ne retirer aucun couvercle de protection sans d'abord débrancher l'appareil et ainsi empêcher l'alimentation d'être rétablie pendant l'entretien.
-  **WARNING!** Do not use in aerospace or nuclear applications.
-  **AVERTISSEMENT!** Ne pas utiliser pour les applications aérospatiales ou nucléaires.
-  **WARNING!** The units are not developed to manage capacitive and inductive loads.
-  **AVERTISSEMENT!** Les unités ne sont pas développées pour la conduite de charges capacitatives et inductives.
-  **WARNING!** The power controller's protection rating is IP20 with all covers installed and closed. It must be installed in an enclosure that provides all the necessary additional protections appropriate for the environment and application.
-  **AVERTISSEMENT!** L'indice de protection du régulateur de puissance est de IP20 lorsque les couvercles sont installés et fermés. L'appareil doit être installé dans une enceinte qui assure toute la protection supplémentaire nécessaire pour l'environnement et l'application.
-  **WARNING!** Ground the power controller via the provided protective earth grounding terminal. Verify ground is within impedance specifications. This should be verified periodically.
-  **AVERTISSEMENT!** Mise à la terre du régulateur de puissance par le biais de la borne de prise de terre de protection fournie. Vérifier que la prise de terre est conforme aux spécifications de l'impédance. Cela doit être vérifié périodiquement.
-  **WARNING!** Electric Shock Hazard: when the power controller has been energized, after shutting off the power, wait at least one minute for internal capacitors to discharge before commencing work that brings you in to contact with power connections or internal components.
-  **AVERTISSEMENT!** Risque de décharges électriques: lorsque le régulateur de puissance est mis sous tension, après avoir été éteint, attendre au moins une minute pour que les condensateurs internes se déchargent avant de commencer tout travail incluant le contact avec les connexions électriques ou les composants internes.
-  **WARNING!** The installation must be protected by electromagnetic circuit breakers or by fuses. The semiconductor fuses located inside the power controller are classified for UL as supplementary protection for semiconductor devices. They are not approved for branch circuit protection.
-  **AVERTISSEMENT!** L'installation doit être protégée par des disjoncteurs électromagnétiques ou des fusibles. Les fusibles pour semi-conducteurs situés à l'intérieur du régulateur de puissance sont classés UL comme protection supplémentaire pour les dispositifs pour semi-conducteurs. Ils ne sont pas approuvés pour la protection des circuits de dérivation.
-  **WARNING!** When making live voltage or current measurements, use proper personal protective equipment for the voltages and arc-flash potentials involved.

-  **AVERTISSEMENT!** Au moment de relever des mesures de tension ou de courant en direct, utiliser un équipement de protection individuelle approprié pour les tensions et les potentiels d'arc électrique concernés.
-  **WARNING!** Verify the voltage and current ratings of the power controller are correct for the application.
-  **AVERTISSEMENT!** Vérifier que les valeurs de tension et de courant du régulateur de puissance sont correctes pour l'application.
-  **CAUTION:** To avoid compromising the insulation, do not bend wire or other components beyond their bend radius specifications.
-  **ATTENTION:** Pour éviter de compromettre l'isolation, ne pas plier le fil ou tout autre composant au-delà de ses spécifications en matière de rayon de courbure.
-  **CAUTION:** Protect the power controller from high temperature, humidity and vibrations.
-  **ATTENTION:** Protéger le régulateur de puissance contre les températures élevées, l'humidité et les vibrations.
-  **CAUTION:** The power controller warranty is void if the tested and approved fuses are not used.
-  **ATTENTION:** La garantie du régulateur de puissance est nulle si aucun fusible testé et approuvé n'est utilisé.
-  **CAUTION:** Only trained and authorized personnel should access and handle the internal electronics and they must follow proper electro-static prevention procedures.
-  **ATTENTION:** Seul le personnel formé et autorisé peut accéder aux composants électroniques internes et les gérer, et il doit se conformer à des procédures de prévention électrostatique appropriées.
-  **CAUTION:** Install an appropriately sized RC filter across contactor coils, relays and other inductive loads.
-  **ATTENTION:** Installer un filtre RC de dimensions appropriées sur les bobines du contacteur, les relais et autres charges par induction.
-  **CAUTION:** The thyristor units here described have been designed for use with sinusoidal networks with nominal frequency 50-60 Hz. Any application with NON-SINUSOIDAL, distorted or disturbed networks could compromise the correct operation of the unit.
-  **ATTENTION:** Les unités de thyristors décrites ici ont été conçues pour être utilisées avec des réseaux sinusoïdaux d'une fréquence nominale de 50 à 60 Hz. Toute application utilisant des réseaux NON SINUSOÏDAUX, déformés ou perturbés peut compromettre le bon fonctionnement de l'appareil.
-  **NOTE:** Provide a local disconnect to isolate the power controller for servicing.
-  **REMARQUE:** Fournir une déconnexion locale afin d'isoler le régulateur de puissance pour l'entretien.
-  **NOTE:** The nominal current is specified for ambient temperatures at or below 40° C. Ensure the application design allows for adequate cooling of each power controller. The power controller must be mounted vertically. The cooling design must prevent air heated by one power controller from causing power controllers mounted above to exceed the ambient operating temperature limit. When power controllers are mounted side by side allow a minimum spacing of 15mm between them.
-  **REMARQUE:** Le courant nominal est précisé pour des températures ambiantes égales ou inférieures à 40°C. S'assurer que la conception de l'application permette le refroidissement adéquat de chaque régulateur de puissance. Le régulateur de puissance doit être monté verticalement. La conception de refroidissement doit empêcher l'air chauffé par le régulateur de puissance de dépasser la limite de température de fonctionnement ambiante de la part des régulateurs de puissance montés au-dessus. Lorsque les régulateurs de puissance sont montés côte à côte, il faut conserver un espacement minimal de 15 mm entre les deux.
-  **NOTE:** Use only copper cables and wires rated for use at 75°C or greater.
-  **REMARQUE:** N'utiliser que des câbles et des fils en cuivre pour l'utilisation à 75°C ou plus.



Maintenance

In order to have a corrected cooling, the user must clean the heat-sink and the protective grill of the fans. The frequency of this servicing depends on environmental pollution.

Also check periodically if the screw for the power cables and safety earth are tightened correctly (See Connection Diagram)

Warranty condition

Producer gives a 12 months warranty to its products.

The warranty is limited to repairing and parts substitution in our factory and does exclude products not properly used and fuses.

Warranty does not include products with serial numbers deleted. The faulty product should be shipped to Producer at customer's cost and our Service will evaluate if product is under warranty terms.

Substituted parts remain of Producer property.



Return Material Authorization (RMA)

Customers wishing to return any items, whether they are incorrectly supplied, faulty or damaged in transit, must first complete a Return Material Authorisation (RMA) form to obtain an RMA number from the Service Department.

A full repair service is available for customers. Prior to submitting the RMA form and returning products, customers are recommended to contact the technical support team to determine whether the issue can be resolved with telephone support.

How the RMA service works

The RMA form and details are available on our web sites:

<https://www.cdautomation.com/returns-material-authorisation/>

When completing the RMA form, please be as specific as possible about the problem, including any pertinent application details. The more information given, the more quickly and more thoroughly the problem can be solved. The minimum information required is:

1. The Full Model Number
2. Quantity of units being returned
3. The units Serial Number(s)
4. A description of the problem ("faulty" or "unknown" is not sufficient)



Summary

- Declaration of conformity3
- Important warnings for safety4
- Maintenance7
- 1 Quick Start9
 - 1.1 Standard version9
- 2 Basic Connections and sizing10
- 3 Identification and Order Code11
 - 3.1 Identification of the Unit11
 - 3.2 Order Code12
- 4 Technical Specification13
 - 4.1 General features13
 - 4.2 Input features13
 - 4.3 Power output features13
 - 4.4 Environmental installation conditions14
 - 4.5 Derating curve14
- 5 Installation15
 - 5.1 Dimensions and fixing holes15
- 6 Wiring instructions17
 - 6.1 Diagram of control connection18
- 7 Fuses and Fuse holder21

1

Quick Start

1.1 Standard version



Attention: this procedure must be carried out by skilled people only.

If the Order Code of the Thyristor unit is in line with what you really need, then CD3000S has been already configured in Factory and you just need to do the following steps:

1. Verify CD3000S Sizing. Be sure that:
 - The load current is equal or less than the Max current of CD3000S.
 - The load voltage is equal or less than the Max voltage of CD3000S
2. Verify the Order Code
3. Verify the Installation
4. Verify the Diagram of control connection:
 - verify that there isn't a short circuit on the load
 - verify the Fan Power Supply (only for sizes S6 and S8)
5. Supply the Power unit

The CD3000S is ready to start

2

Basic Connections and sizing

Star Wiring with resistive Load

$$I = \frac{P}{1,73V}$$

V = Nominal load voltage phase to phase

I = Nominal current of the load

P = Nominal power of the load

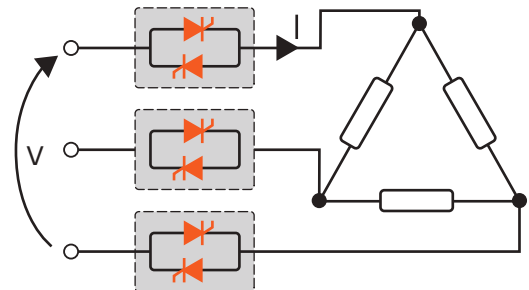

Delta Wiring with resistive Load

$$I = \frac{P}{1,73V}$$

V = Nominal load voltage phase to phase

I = Nominal current of the load

P = Nominal power of the load

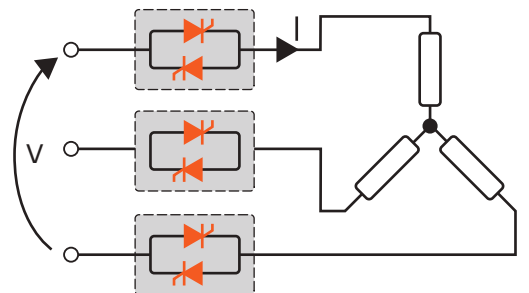

Open Delta Wiring with resistive Load

$$I = \frac{P}{3V}$$

V = Nominal load voltage phase to phase

I = Nominal current of the load

P = Nominal power of the load

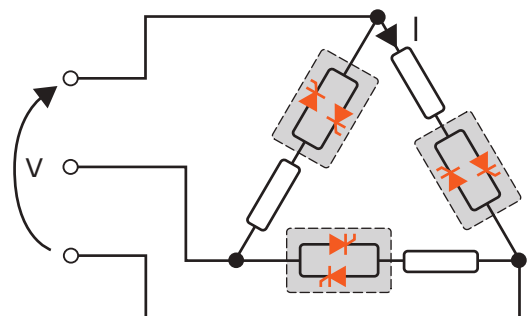

3 Identification and Order Code

3.1 Identification of the Unit



Caution: Before to install, make sure that the Thyristor unit have not damages. If the product has a fault, please contact the dealer from which you purchased the product.

The identification label give all the information regarding the factory settings of the Thyristor unit, this label is on the unit, like represented in figure.

Verify that the product is the same thing as ordered.

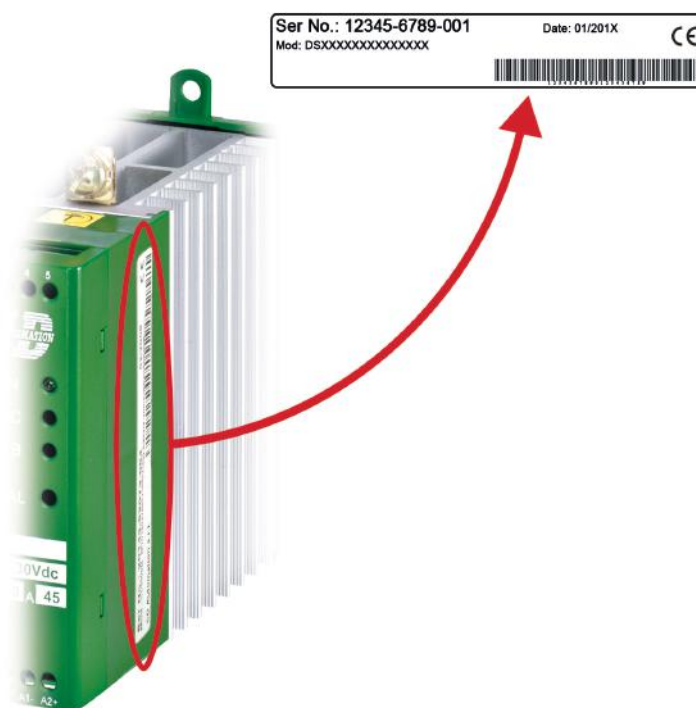

3.2 Order Code

	1	2	3	4	5	6		7	8	9	10	11	12	13	14	15	16
CD3000S 3PH	D	S	3	-	-	-	-	-	-	-	-	-	-	-	-	-	-

CURRENT (A)				CONTROL MODE			
description	Code	OLD code	Note	description	Code	OLD code	Note
15A	0 1 5	15A		Open loop	0	not in the code	
30A	0 3 0	30A		FUSES & OPTION			
45A	0 4 5	45A		description	Code	OLD code	Note
60A	0 6 0	60A		No Fuse	0	NF / -	
75A	0 7 5	75A		External Fuse & Fuse Holder	F	EF / -	
90A	0 9 0	90A		FAN VOLTAGE			
OPERATING VOLTAGE (V)				description	Code	OLD code	Note
-				No Fan for unit <45A	0	- /	
description	Code	OLD code	Note	Fan 110V Option - for 45A to 90A units	1	110VFAN/	
From 24V to Max Load Voltage	not in the code	__ _V		Fan 220V Standard - for 45A to 90A units	2	not in the code	
MAX LOAD VOLTAGE (V)				APPROVALS			
description	Code	OLD code	Note	description	Code	OLD code	Note
480V	4			CE EMC for European Market	0	- /	
600V	6			CE EMC + cUL us listed	L	UL /	
AUXILIARY VOLTAGE (V)				MANUAL			
description	Code	OLD code	Note	description	Code	OLD code	Note
NO Auxiliary Voltage supply	0	NO /		None	0	NM	
INPUT				Italian	1	IM	
description	Code	OLD code	Note	English	2	EM	
SSR	S	SSR /		German	3	GM	
FIRING				French	4	FM	
description	Code	OLD code	Note	IP PROTECTION			
Zero Crossing	Z	ZC /		description	Code	OLD code	Note
				Standard IP20 (all unit excluded 45A to 90A)	0	- /	
				External IP20 protection for size S8 (45A to 90A)	P	EP /	1

(1) IP20 is standard on all units with exception of S8 size (45-90A). To complain IP20 use "P" option at digit 16

New Code (example):

	1	2	3	4	5	6		7	8	9	10	11	12	13	14	15	16
CD3000S 3PH	D	S	3	0	9	0	-	4	0	S	Z	0	F	2	L	2	P

Old Code (example):

Model	Current (A)	Operating Voltage (V)	Max Load Voltage (V)	Aux Voltage (V)	Input	Firing	Fuses	Fan	EP Option	Approvals	Manual
CD3000S 3PH /	90A /	400V /	480V /	NO /	SSR /	ZC /	EF /	- /	EP /	UL /	EM

4

Technical Specification

4.1 General features

Cover and Socket material:	PolymericV2
Heat-sink:	Anodized aluminum
Delay switch ON time:	0.5 period Max
Delay switch OFF time:	0.5 period Max
Auxiliary Voltage:	12÷24V dc/ac (max 70mA)
Fan Voltage (only for Size S8)	220Vac ± 15% (110 Vac option)

4.2 Input features

Analog Input: (Loop Powered)	4 - 20mA (6,5Vdc Min)
Logic input SSR: (Standard for size S0-S1)	4 - 30Vdc 20mA Max (ON ≥ 4Vdc - OFF < 1Vdc)
Logic input SSR: (Standard for size S4-S7-S8)	4 - 30Vdc 15mA Max (ON ≥ 4Vdc - OFF < 1Vdc)
Logic input SSR: (low current)	5 - 30Vdc 12mA Max (ON ≥ 5Vdc - OFF < 1Vdc)

4.3 Power output features

Size	Voltage range	Repetitive peak reverse Voltage		Latching current	Max peak one cycle	Leakage current	I ² T value thyristor	Frequency range	Power loss	Isolation Voltage
		480V	600V							
(A)	(V)	480V	600V	(mAeff)	(10ms) (A)	(mAeff)	tp=10msec	(Hz)	I=Inom (W)	Vac
15A (S2)	24÷480	1200	1200	150	230	15	610	47÷70	54	2500
30A (S4)	24÷480	1200	1600	250	600	15	1800	47÷70	108	2500
45A (S6)	24÷600	1200	1600	250	600	15	1800	47÷70	162	2500
60A (S8)	24÷600	1200	1600	450	1000	15	4750	47÷70	216	2500
75A (S8)	24÷600	1200	1600	450	1540	15	11300	47÷70	270	2500
90A (S8)	24÷600	1200	1600	450	2000	15	19100	47÷70	324	2500

4.4 Environmental installation conditions

Ambient temperature	0-40°C (32-104°F) at nominal current. Over 40°C use the derating curve.
Storage temperature	-25°C to 70°C, -13°F to 158°F
Installation place	Don't install at direct sun light, where there are conductive dust, corrosive gas, vibration or water and also in salty environmental.
Altitude	Up to 1000 meter over sea level. For higher altitude reduce the nominal current of 2% for each 100m over 1000m
Humidity	From 5 to 95% without condense and ice
Pollution Level	Up to 2nd Level ref. IEC 60947-1 6.1.3.2

4.5 Derating curve

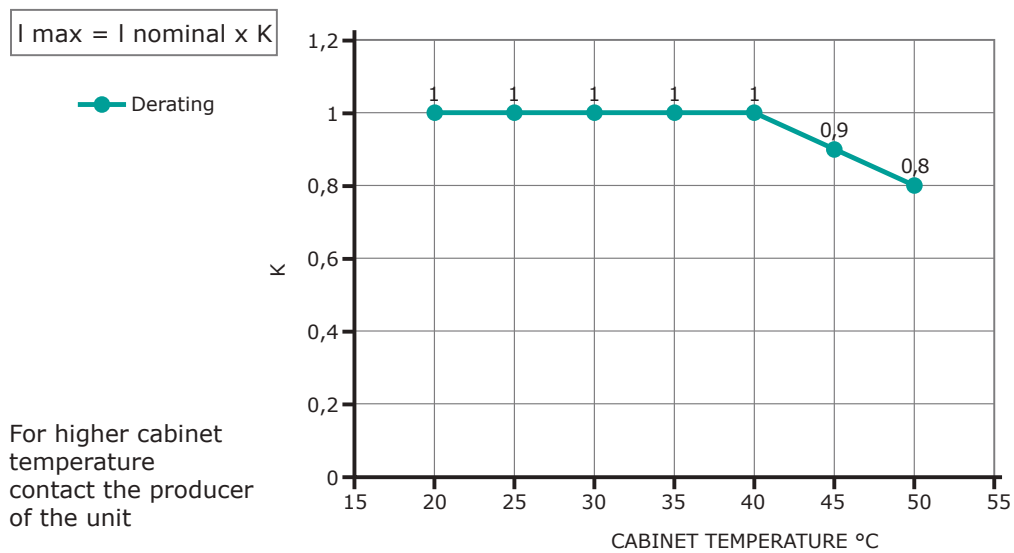

5

Installation

Before to install, make sure that the Thyristor unit have not damages.

If the product has a fault, please contact the dealer from which you purchased the product. Verify that the product is the same thing as ordered.

The Thyristor unit must be always mounted in vertical position to improve air cooling on heat-sink.

Maintain the minimum distances in vertical and in horizontal as represented.

When more unit has mounted inside the cabinet maintain the air circulation like represented in figure.

Sometimes is necessary installing a fan to have better air circulation.

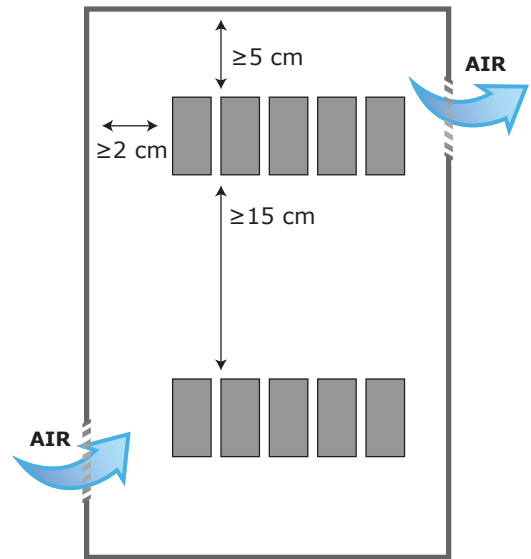

5.1 Dimensions and fixing holes

Size: S2

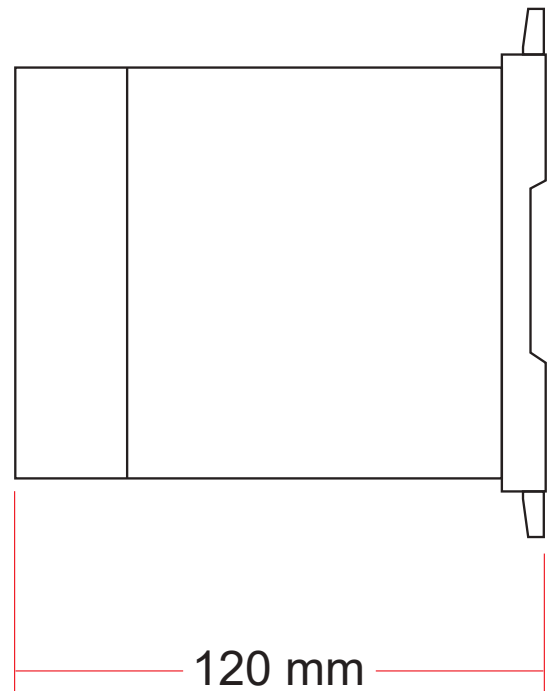
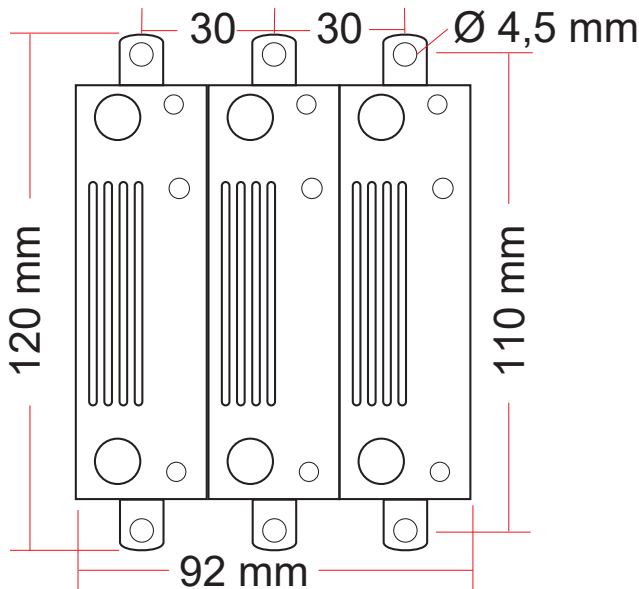

Size: S4

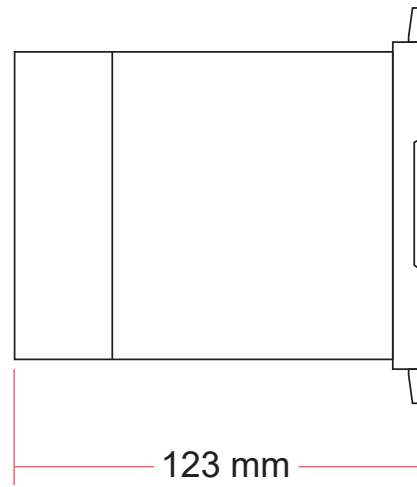
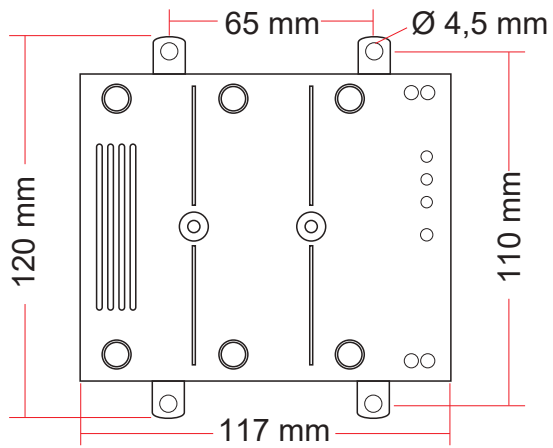

Size: S6

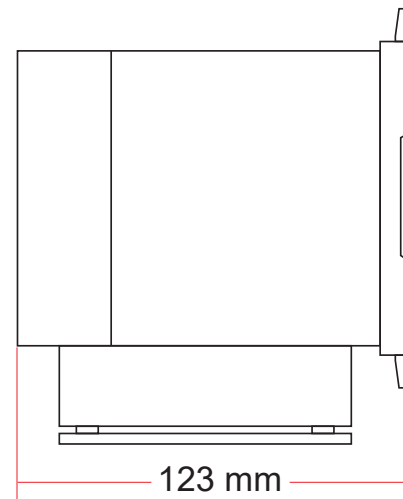
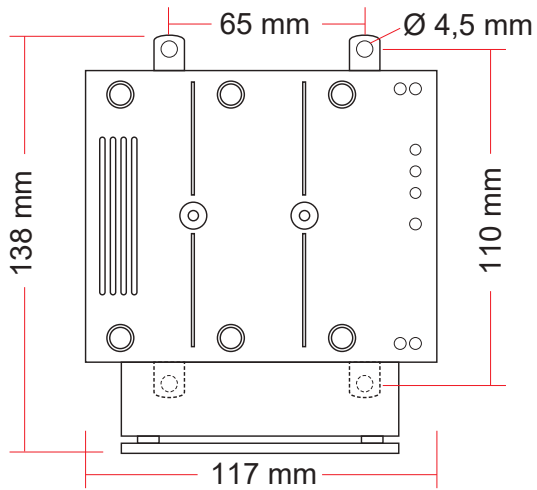

Size: S8

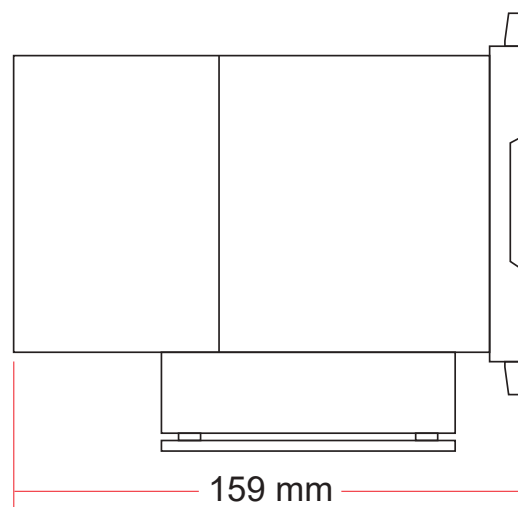
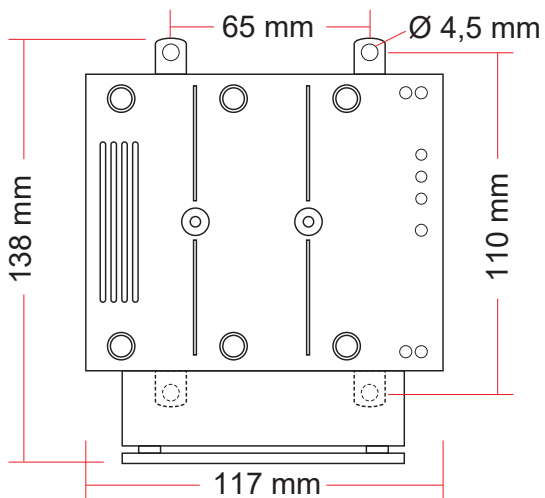

6

Wiring instructions

CD3000S unit has isolated heatsink. For safety connect the heatsink to earth using its terminal with earth symbol.

CD3000S can be susceptible to airborne interferences from near equipment or from interferences on main supply, so a number of precautions must be taken.

- Contactors coils and chokes must have in parallel a RC filter and must be supplied with a different voltage line.
- All input/output signals must use screened bifilar wires.
- Signal input and output must not route in same cable try and must not be parallel.
- Local regulations regarding electrical installation should be rigidly observed

Use copper cables and wires rated for use at 75 °C only.

Use wire terminal UL Listed (ZMVV).

Power cable torque (suggested)

Current	Connector Type	Torque Lb-in (N-m)	Wire Range AWG/kcmil	Wire Terminal UL listed (ZMVV)
15A, 30A, 45A	M5 Screw	26.6 (3.0)	8	Wire Pin
60A, 75A, 90A	M6 Screw	70.8 (8.0)	1	Fork/Spade terminal Copper Tube Crimp. Lug

Cable dimensions (suggested)

Current	Supply			Load			Earth			Auxiliary Supply	
	Cable		Screw M	Cable		Screw M	Cable		Screw M	Cable	
	mm ²	AWG		mm ²	AWG		mm ²	AWG		mm ²	AWG
15A (S2)	4	12	M5	4	12	M5	4	12	M5	0,50	18
30A (S4)	6	10	M5	6	10	M5	6	10	M5	0,50	18
45A (S6)	10	8	M5	10	8	M5	6	10	M5	0,50	18
60A (S8)	16	6	M6	16	6	M6	6	10	M5	0,50	18
75A (S8)	25	4	M6	25	4	M6	6	10	M5	0,50	18
90A (S8)	35	3	M6	35	3	M6	6	10	M5	0,50	18

6.1 Diagram of control connection

Load type

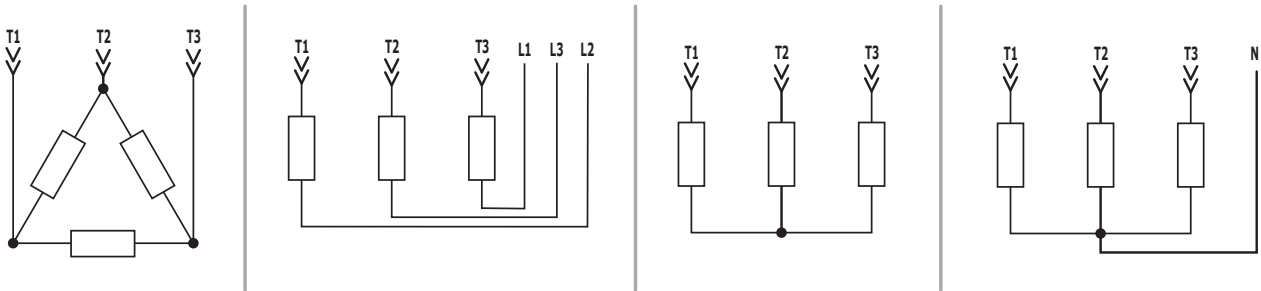

Size S2 - 15A

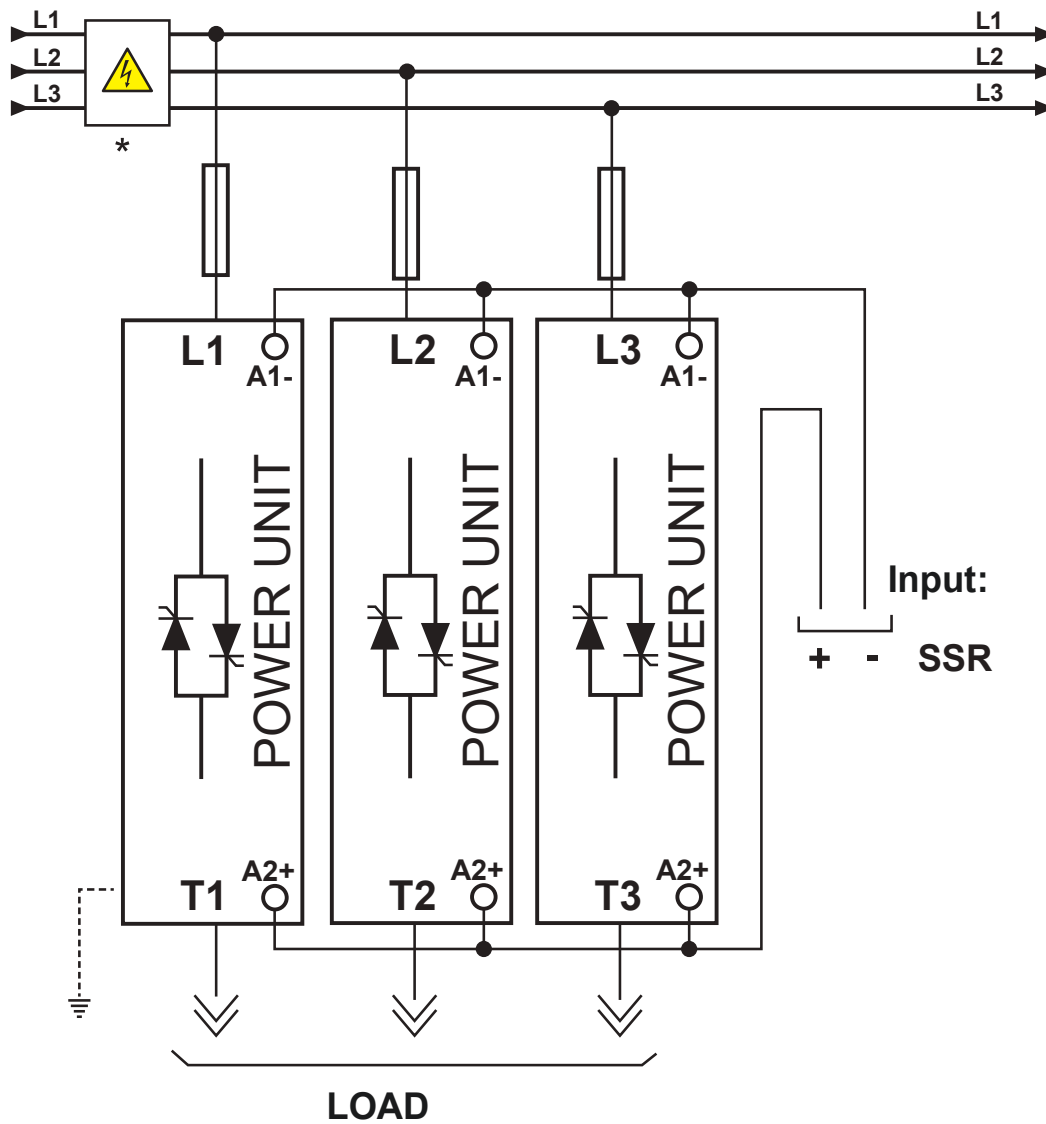

Note:

The user installation must be protected by electromagnetic circuit breaker or by fuse isolator.

Size S4 - 30A

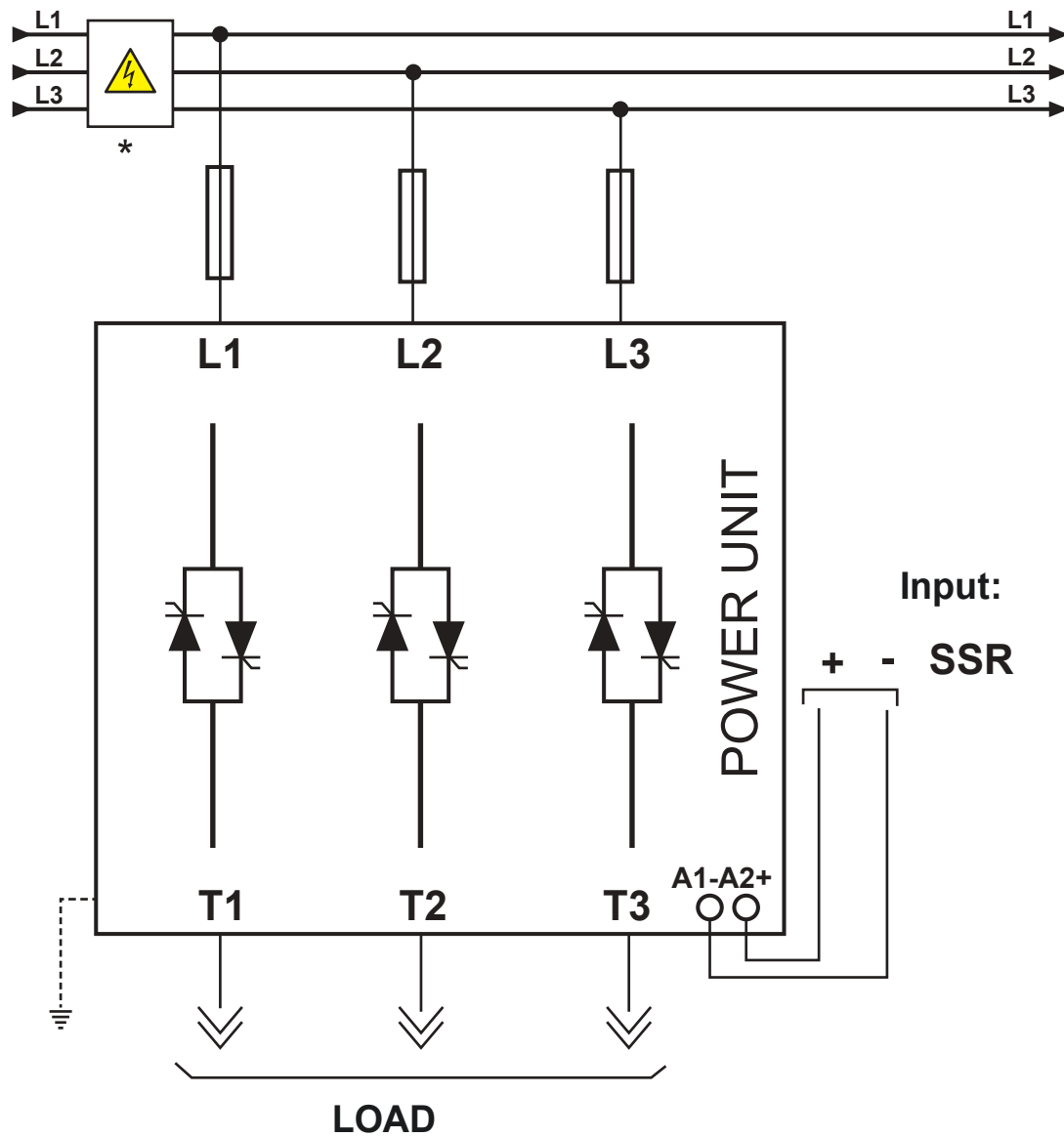

Note:

The user installation must be protected by electromagnetic circuit breaker or by fuse isolator.

Size S6 - 45A

Size S8 - 60A, 75A, 90A

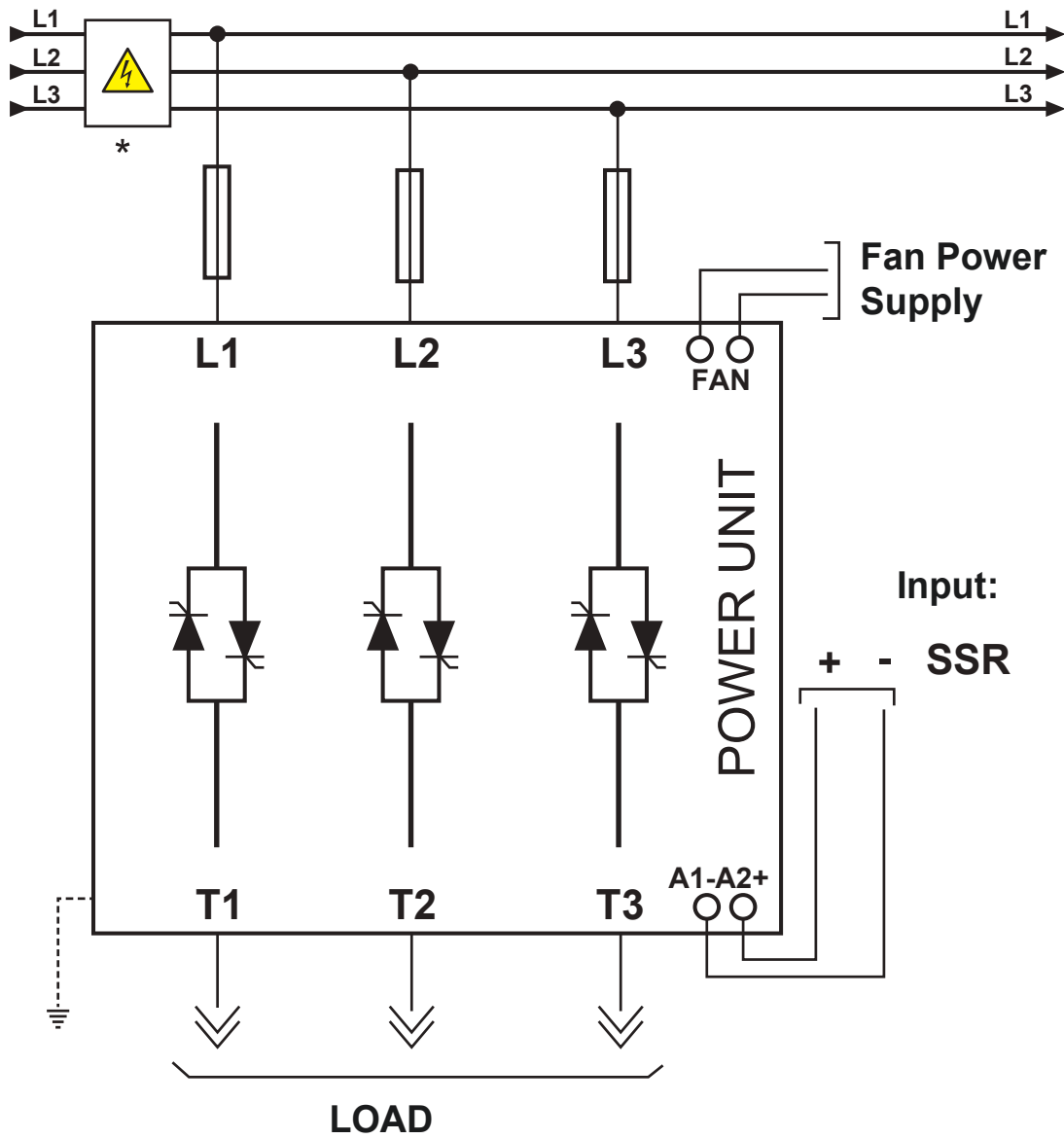

Note:

The user installation must be protected by electromagnetic circuit breaker or by fuse isolator.

7

Fuses and Fuse holder



Warning: High speed fuses are only used for the thyristor protection and can not be used to protect the installation.

CD3000S unit must be protected against short circuit by High speed fuses.
The Fuses must have I^2T 20% less than thyristor's I^2T .
The warranty of thyristor is null if no proper fuses are used. See tab.

Fuses and Fuse holder Code for CE

Size	Fuse Holder Code	Fuse Code	Total Current (A_{RMS})	I^2T ($A^2 \text{ sec.}$)	Quantity for each phase
15A (S2)	FFH1038	FU1038/16A	16	150	1
30A (S4)	FFH1451	FU1451/40A	40	1650	1
45A (S6)	FFH1451	FU1451/50A	50	2000	1
60A (S8)	FFH2258	FU2258/80A	80	6550	1
75A (S8)	FFH2258	FU2258/100A	100	13500	1
90A (S8)	FFH2258	FU2258/125A	125	14000	1

Fuses and Fuse Holder Code for UL

Size	200 kA_{RMS} Symmetrical A.I.C.					Quantity for each phase
	Fuse Holder Code	Fuse Code	Total Current (A_{RMS})	I^2T ($A^2 \text{ sec.}$)	Vac	
15A (S2)	FFH1038	FU1038/16AUL	16	150	600	1
30A (S4)	FFH1451	FU1451/49AUL	40	750	700	1
45A (S6)	FFH1451	FU1451/50AUL	50	1800	700	1
60A (S8)	FFH2258	FU2258/80AUL	80	6600	700	1
75A (S8)	FFH2760	FU2760/100AUL	100	3210	660	1
90A (S8)	FFH2760	FU2760/125AUL	125	6970	660	1

Fuse Holder size

15A

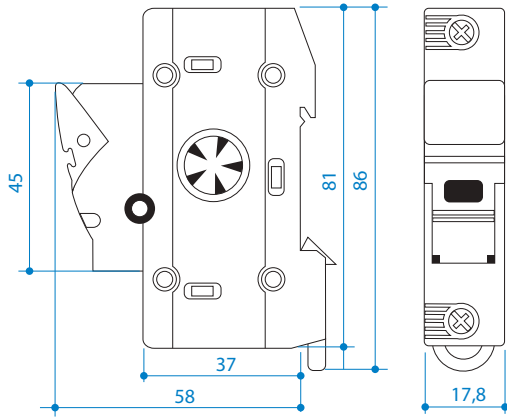

30A, 45A

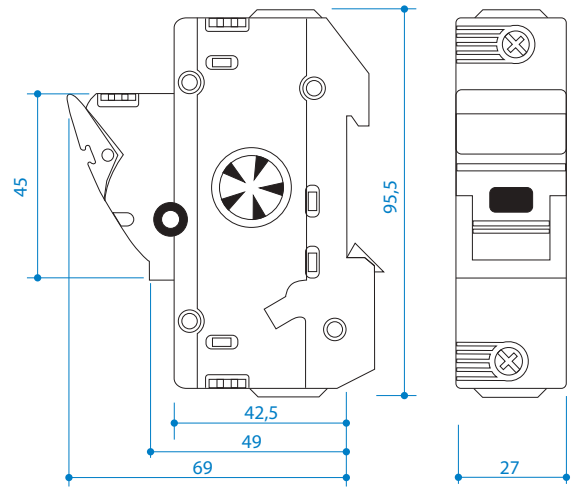

60A-90A (CE)

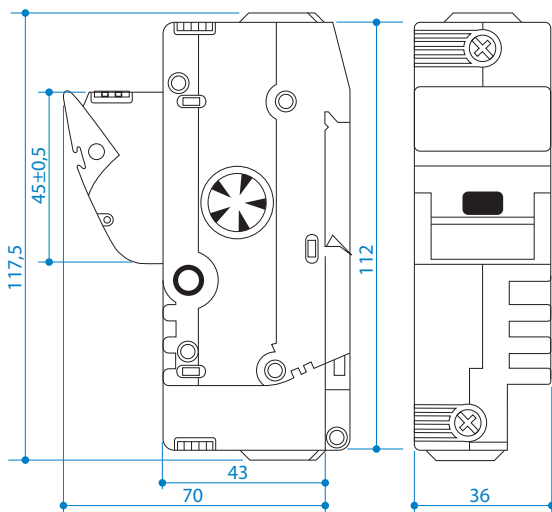

75A (UL) -90A (UL)

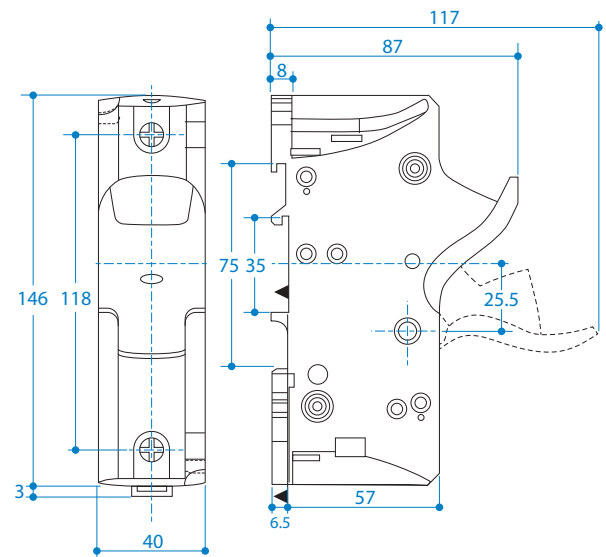



CD Automation S.r.l.

Via Picasso, 34/36 - 20025 Legnano (MI) - Italy

Tel. +39 0331 577479 - Fax +39 0331 579479

E-mail: info@cdautomation.com - Web: www.cdautomation.com